

Event-based Addressing for Information Distribution in Dynamic Networks

Cornelia Kappler
deZem GmbH
Berlin, Germany
cornelia.kappler@dezem.de

Kostas Pentikousis
VTT Technical Research Centre of Finland
Oulu, Finland
kostas.pentikousis@vtt.fi

Carlos Pinho
Telecommunications and Multimedia
INESC Porto
Porto, Portugal
cpinho@inescporto.pt

Abstract—A salient feature of upcoming communication networks is unprecedented dynamicity, which can only be handled in a large scale by introducing self-configuration and self-maintenance mechanisms. The main contribution of this paper is the definition of a protocol toolbox for efficiently supporting communication for self-configuration and self-maintenance in dynamic environments. We leverage our experience from developing trigger management mechanisms for mobility control and extend the Generic Ambient Network Signaling protocol by defining a new Routing Method, the event-based Routing Method.

Keywords—Network Composition; NSIS; GANS; Event Notification; Triggering; Self-X

I. INTRODUCTION

A salient feature of upcoming communication networks is unprecedented dynamicity with respect to both type of constituent nodes and topology. Mobile nodes can form ad-hoc and, possibly, mobile networks, where new nodes can join and leave at will. Examples of such dynamic networks include access networks in trains and airplanes; spontaneously formed vehicular area networks; and personal and body area networks. Opportunistic and collaborative communication networks, a very promising but nascent research field, will introduce even more dynamicity.

The trend for more dynamicity has been spotted by designers of mobile telecommunication networks that traditionally depended on fixed topologies, structures, and agreements to deliver services. For example, the current System Architecture Evolution (SAE) [1] work in 3GPP describes a generic way for including alternative access networks in a 3G operator's offerings. A recent 3GPP feasibility study points out how such alternative accesses could be added in a dynamic fashion [2]. This 3GPP study borrows the *network composition* concept from the work done in the EU Sixth Framework Programme project Ambient Networks (see [3][4] and www.ambient-networks.org). Network composition enables networks to dynamically negotiate and agree on ways to cooperate. It particularly addresses cooperation in the control plane, for example, regarding mobility and security, and within the Ambient Networks project it has been developed for more general scenarios of dynamically extensible networks (see [5][6] for more details).

This anticipated network dynamicity can only be handled in a large scale by introducing self-configuration and self-maintenance mechanisms. For example, adding and removing network nodes or entire sub-networks must involve human administrators as little as possible and for specific tasks such as the initial authorization of the process. The routing protocols for ad-hoc networks standardized by the IETF MANET working group [7] already follow this approach and function without manual configuration.

Generally speaking, self-configuration, self-maintenance, and other “self-X” properties, such as self-optimization, self-adaptation, self-management, and self-healing, to name a few, require communication between the nodes. An important aspect of this communication in dynamic environments is that each node joining the network typically has little, if any, *a priori* information, particularly with respect to which other network elements are available, and how can they be reached, that is, what is their routable address. By the same token, nodes that are part of a dynamic network do not necessarily maintain a complete and up-to-date list of all nodes currently reachable.

In environments with a well defined, static infrastructure, the IP address of the communication partner can be resolved using DHCP or DNS queries. This, however, is not an option in dynamic and often short-lived environments. Broadcasting, often employed as a remedy in such dynamic environments, has its own shortcomings and introduces system inefficiencies. The main contribution of this paper is the definition of a protocol toolbox for supporting communication for self-configuration and self-maintenance in dynamic environments in a more targeted way than by broadcasting. The proposed toolbox is generic enough to allow designers of self-configuration mechanisms to forego developing custom-made, problem-specific protocols from scratch and instead focus on other aspects of network design.

The rest of this paper is organized as follows. Section II describes the problem in more detail and surveys several existing solutions. Section III introduces our approach, which is based on an extension of the NSIS (Next Steps in Signaling) protocol framework, contrasting it with previous work. Section IV details our protocol design. Finally, Section V summarizes the main contributions of this paper, discusses our results, and outlines future items of work.

II. PROBLEM DESCRIPTION AND RELATED WORK

In this section we discuss the problem of network element communication in dynamic environments with self-configuration and self-maintenance as critical characteristics, and survey specific solutions for ad-hoc and mobile networks.

As mentioned above, the IETF-standardized routing protocols for ad-hoc networks are self-configuring and self-maintaining. This is achieved by employing periodical broadcasting and active polling. Each mobile node continuously collects information about its neighbors in order to maintain its routing table up-to-date. When a node leaves the ad-hoc network, the remaining nodes notice this event only after a while, as the process depends on time outs. After detecting a node's absence, the remaining nodes adapt their routing tables accordingly [7].

An alternative approach is taken by the IETF Network Mobility (NEMO) working group. In this set of proposals, mobility (and dynamicity) is supported by a mobile router, which makes network access-related events transparent to the constituent nodes. For example, in the basic case, network mobility is transparent to all mobile network nodes except the mobile router. In other words, the nodes comprising the mobile network can use their own mobility management protocol or even no protocol at all, and they are not aware that the network is mobile [8]. Hence, no extra configuration and communication is necessary between the mobile router and other nodes in the mobile network. Nevertheless, mobility support beyond basic mobility, say, routing optimization, presumably requires further coordination and communication. This problem is yet to be addressed by the NEMO working group.

Yet another approach is adopted by the IEEE 802.21 information service, currently under standardization [9], for media-independent handovers where the intelligence for handling dynamicity is located in the static part of the network. The IEEE 802.21 information service is defined to support optimal network selection across multiple different network access technologies. In the typical use case, a mobile node on the lookout for better network access can query the service for information on available accesses. In fact, a node can use this service even if it knows little about the surrounding network structure. The protocol for supporting this service is developed by the MIPSHOP working group of the IETF. The currently favored solution [10] asserts that the mobile node performs a DNS or DHCP query for locating the IEEE 802.21 information service. An alternative solution suitable for fully dynamic environments—based on an approach similar to the one proposed in this paper—has also been discussed [11]. Along the same lines, a generic notification framework was proposed in [12] which can handle mobility triggers originating from any protocol layer and any mobility management entity within the network.

More generally, we expect that new and additional mechanisms for self-configuring dynamic networks will be developed. The solution discussed above either work using broadcasting, or have yet to consider fully dynamic environments. The following section introduces our solution approach which addresses the issues at hand in a generic way.

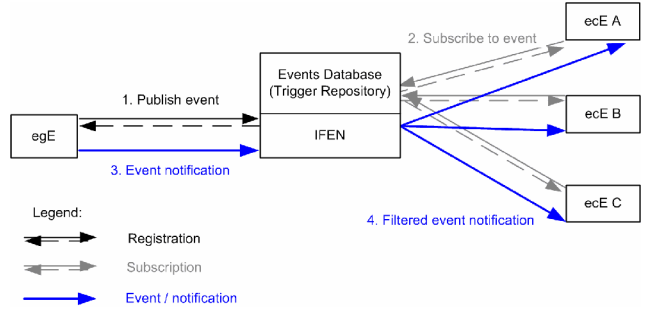

Figure 1. High-level view of IFEN

III. SOLUTION APPROACH

We argue that a key communication pattern in dynamic environments employing several heterogeneous network access technologies is the exchange of event notifications. In [12], a building block for self-maintained mobility management in dynamic environments was proposed, accompanied by a lab prototype implementation called TRG. This block is essential when building an infrastructure for distributing notifications of mobility-related events that may trigger a handover. Events can originate from both the network and the mobile node and any functional entity or protocol. Network event examples include the availability of a new network access, network access cost changes, and others resulting from load balancing and resource management mechanisms. On the other hand, the mobile node can signal to the network that certain performance parameters are not up to par, leading to mobility management actions.

In this paper, we extend and generalize the work in [12] by defining a generic Inter-function Event and Notification functional entity (IFEN). IFEN borrows from TRG a few elements. For example, event-generating entities (egE's) register events with IFEN (Fig. 1, step 1). When new event information comes in, it is stored in a database maintained by IFEN. Meanwhile, event-consuming entities (ecE's) can subscribe to the events they are interested in (Fig. 1, step 2). When an event occurs, the egE alerts IFEN (Fig. 1, step 3), which would consequently apply filters and policies as necessary, and proceed distributing the event to the corresponding ecE's (Fig. 1, step 4). These two classes of entities, egE's and ecE's, can be mapped to TRG producers and consumers, respectively. Nonetheless, a fundamental difference between IFEN and TRG is that the latter is concerned with mobility management events only. Furthermore, no protocol has been worked out in [12] to support event distribution.

The aim of this work is to develop a generic protocol toolbox for supporting communication for self-configuration and self-maintenance in dynamic environments, which works both in the presence of IFEN and without it. In the latter case, egE's directly distribute events to ecE's. We base our work on the protocol framework developed by the Next Steps in Signaling (NSIS) [13] working group of the IETF. In previous work we described an extension to NSIS, the Generic Ambient Network Signaling protocol (GANS), suitable for a broader range of environments [14]. A distinguishing feature of GANS

is the usage of abstract addressing based on roles. In this paper, we add another addressing scheme to GANS, event-based addressing, that is particularly useful in self-X environments.

The following subsection overviews the NSIS and GANS protocol frameworks, centering particularly on their respective addressing schemes. Then, in subsection III.B, we present the core of this paper, the introduction of event-based addressing for GANS.

A. The NSIS and GANS Protocol Frameworks

NSIS is a general-purpose signaling protocol suite for the manipulation of data flow-related control state in network nodes: for a given session, signaling messages are exchanged between the network nodes on the data flow's path. The key NSIS idea is a layered protocol design [13], as illustrated in Fig. 2. The NSIS Transport Layer Protocol (NTLP) provides common functionality for the routing of signaling messages. This includes locating network nodes that are eligible for controlling the flow for this signaling session. Eventually, NTLP installs a secure signaling overlay that allows routing NSIS messages back and forth between the identified network nodes along the flow path. The upper protocol layer accommodates the actual information that is being signaled in different NSIS Signaling Layer Protocols (NSLPs), see Fig. 2. An example of an NSLP is a protocol for signaling QoS. Another example is an NSLP for controlling firewalls and Network Address Translators (NATs). NSIS uses the services provided by transport protocols (UDP or TCP, as appropriate) as well as security protocols like IPsec and TLS, when necessary.

The NSIS protocol suite is designed to control data flows. In the context of the Ambient Networks project, its scope was broadened to carry control information that is not bound to a particular flow, such as, for example, signaling for negotiating Service Level Agreements (SLA). This generalized protocol is called GANS and is presented in detail in [14]. Similarly with NSIS, GANS has a two-layer architecture. While GANS is backwards compatible with NSIS, the changes are sufficiently significant to merit a renaming of the layers. The GANS upper layer is called GSLP; the lower layer is called GTLP. Like NTLP, GTLP is responsible for setting-up and maintaining the signaling overlay. GSLPs contain the actual signaling semantics, say, for SLA signaling.

Overall, a central difference between GANS and NSIS is how nodes are identified in order to process a signaling message and create control state. Generally, the upper layer (NSLP or GSLP) informs the lower layer (NTLP or GTLP, respectively) about the so-called Routing Method and about the identifiers of relevant network nodes in an object called Message Routing Information (MRI). The NTLP protocol has been designed such that the Routing Method is a modular component that can be exchanged [15].

In NSIS, the node identifier contained in the MRI is always an IP address. For example, when the Path-coupled Routing Method is used, the MRI contains the IP address of the receiver of the data flow. If it is the first NSLP message to this receiver, i.e. if the signaling overlay has not yet been set up, NTLP sends the message destined to the receiver with a

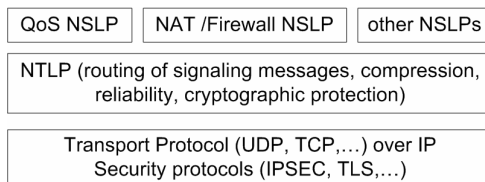

Figure 2. NSIS protocol structure

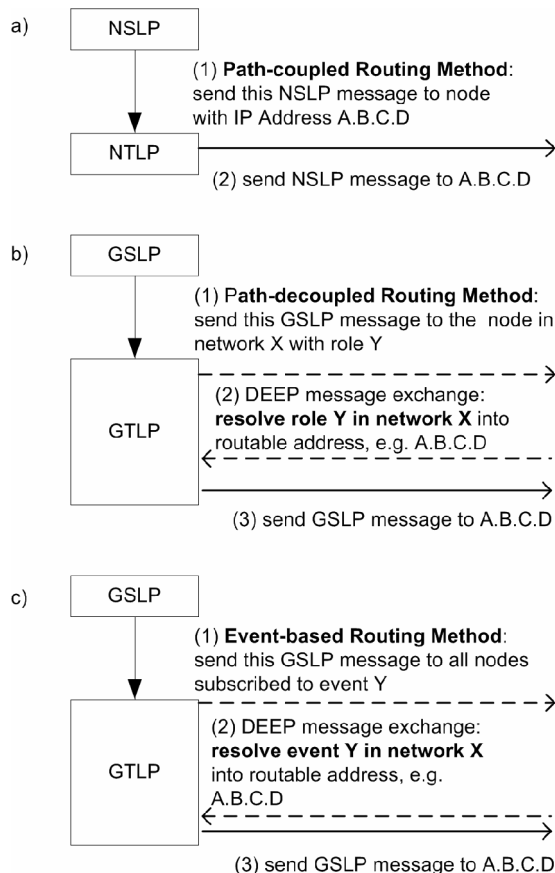

Figure 3. Addressing and name resolution in (a) NSIS, (b) GANS with role-based addressing, and (c) GANS with event-based addressing

Router-Alert-Option turned on. This allows the network nodes on the flow path that shall install control state to become aware of the signaling exchange and to add themselves to the per-flow overlay. As shown in Fig 3a, subsequent messages are exchanged at the NTLP layer by addressing each node in the overlay directly by its IP address.

The GANS protocol, in contrast, is more suitable for dynamic environments, in which only the role of the receiving network element, e.g. “bandwidth broker”, is known but not a routable address, e.g. the broker’s IP address. In addition to other changes, GANS introduces a new Routing Method, the Path-decoupled Routing Method. The MRI for this Routing Method contains a role description rather than an IP address. This difference is illustrated in Fig. 3b.

As an aside, the usual methods for resolving addresses, e.g. DNS, are considered unsuitable for the dynamic environments envisaged. The time needed to update the DNS infrastructure is simply too much. GANS, therefore, employs an additional protocol to resolve the role-to-routable address mapping called Destination Endpoint Exploration Protocol (DEEP) that can work in general name resolution infrastructures. DEEP is detailed in [16][17] and is beyond the scope of this paper.

B. Event-based Addressing for GANS

As explained above, an important communication pattern in heterogeneous environments is the distribution of event notifications. One can assume that in dynamic environments, the event generating entity does not know the role, the identity or the routable addresses of the event consuming entities. In fact, an event-generating entity might not even know which entities may be interested in consuming the events it can generate. We therefore extend the addressing scheme of GANS to include event-based addressing. In technical terms, we add a new Routing Method, the event-based Routing Method.

The basic idea is as follows. As assumed in [12] and illustrated in Fig. 1, the event-generating entity (egE) stores the events it provides in a central location, the events database. Event-consuming entities (ecE) can subscribe to these events. Obviously, the naming of events must be standardized in some way. When an event occurs, the egE constructs a GSLP message with the event details, and passes it to GTLP together with the event ID, as illustrated in Fig. 3c. GTLP calls the DEEP protocol to resolve the event ID into a routable address, and then sends off the GTLP message. If IFEN infrastructure is present, the routable address returned by DEEP is that of IFEN and the event would be sent there to be filtered and prioritized before being distributed further, as illustrated in Fig. 1. Without IFEN, the addresses returned by DEEP are the ones of the ecE's, and GTLP distributes the events to ecE's directly. It is important to note that adding event-based addressing to the original GANS design [14] requires only a minor conceptual generalization that will be explained in subsection IV.A below. Mainly, event-based addressing is realized by introducing a new Routing Method, which is already foreseen in the basic NTLP design [15].

IV. PROTOCOL DESIGN

Generally, we assume the existence of an events database such as the one illustrated in Fig. 4. Using IFEN (cf. Fig 1) egE's store the events they can generate in this database. Also via IFEN, ecE's can subscribe to events they are interested in. The database must store event IDs and the respective egE's and ecE's. For example, in Fig. 4, event 10 is offered by egE X, and is subscribed to by ecE's F and Q. On the other hand, event 55 is offered by egE F, but no entity is interested in being notified at this moment. How the events database is populated and maintained is beyond the scope of this paper.

A. Event Distribution

When an event occurs, the egE needs to inform all subscribed ecE's about the event. Said egE will construct a

EVENT ID	EGE	ECE	DESCRIPTION
1	A	B, F, Q	New network access available
50	B	A, X	Resources preempted
55	F		VoIP call quality below par
10	X	F, Q	Virtual private network (VPN) association established
11	X	Q	Restricted network use; network address and port translator (NAPT) in the path

Figure 4. An example of the events database

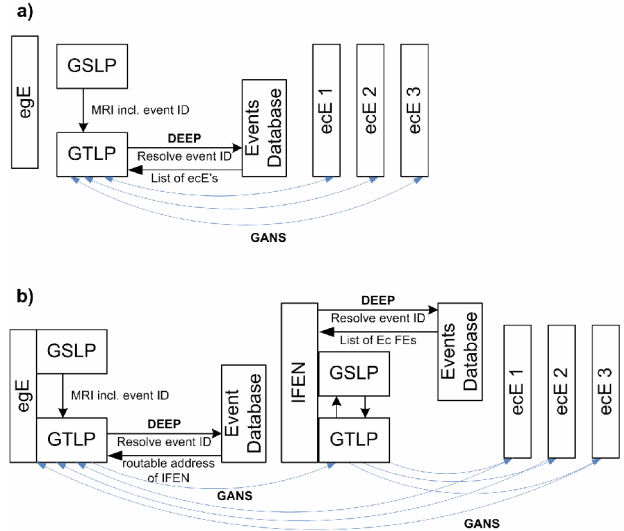

Figure 5. Event distribution (a) without IFEN and (b) with IFEN

GSLP message which contains the event ID in the MRI and will pass it to GTLP. Then, GTLP calls DEEP to resolve the event ID into the routable addresses of the receivers (Fig. 3c).

Compared to the conventional GANS and NSIS operation, this distribution of events has two interesting features. First, more than one ecE's may be interested in a particular event. A single GSLP message thus may result in several GTLP messages. GSLP should, therefore, in a slight generalization of the original GANS design, be prepared to receive several replies to a single message. It may cause concern that the egE does not know how many replies to expect when sending the original message and therefore it does not know when to stop waiting for replies. A possible solution is to introduce a timer at the egE that determines how long to wait. Alternatively, when IFEN is involved, it could send a message to the egE stating the number, and possibly the identifier of the ecE's.

Second, the protocol machinery should work always in the same way, regardless of whether IFEN infrastructure is in place or not. This is illustrated in Fig. 5. Without IFEN (Fig. 5a), when the event message is handed to GTLP, DEEP is invoked. DEEP will return the routable addresses of all subscribed ecE's after checking with the events database. When DEEP returns, GTLP sends the message to all addresses it received from DEEP, e.g. to ecE's 1-3 in Fig. 5a.

When IFEN is present (Fig. 5b), after the event message is handed to GTLP, DEEP will return the routable address of IFEN. Then, GTLP at egE will contact its peer at IFEN, where the event ID is finally resolved into the names of event consuming FEs. The received event notification is filtered and prioritized and then sent on to all subscribed ecE's, eg. to ecE's 1-3 in Fig. 5b. On the return path, IFEN drops out since it is no longer necessary.

B. Discussion

The use of IFEN in the proposed event-based Routing Method for GANS makes for a very compelling solution: From an implementation perspective IFEN can easily be bundled with the events database, providing a single point of reference in the system. We already have experience in developing TRG for mobility management [12], and we are confident that including IFEN as an invariant of the proposed Routing Method is the best option. In [18], we detail our protocol for event distribution and study analytically its performance for different cases. In short, employing IFEN seems to point to significant performance gains. Nevertheless, more work is needed to precisely determine the tradeoffs of such a system design choice.

V. CONCLUSION AND FUTURE WORK

The anticipated unprecedented dynamicity in future mobile networks calls for embracing self-X properties, such as self-configuration and self-maintenance, in order to deliver seamless connectivity, improve the end user's quality of experience, and address the expected order of magnitude increase in the number of connected nodes. We discussed current approaches for dealing with self-configuration and maintenance and identified the ability to deliver event notifications as a key characteristic of any forthcoming solution. We then put forward our proposal to develop a generic protocol toolbox that enables efficient communication for self-configuration and maintenance and is suitable for different contexts.

This paper introduced a new Routing Method for GANS, the Generic Ambient Networks Signaling protocol. The proposed Event-based Routing Method makes use of an events database and can capitalize on the presence of the Interfunction Events and Notifications functional entity (IFEN). In the absence of IFEN, the proposed Routing Method uses the events database only. From an implementation perspective, our preliminary investigation shows that IFEN and the events database can be bundled in a straightforward manner.

Quantifying which is the best implementation option remains an item of future work for us, and will require the development of a prototype. Also part of our future work is a scalability and tradeoff analysis of the two options. By simulating both approaches we shall be able to determine their behavior and performance in different scenarios.

ACKNOWLEDGMENT

This work has been carried out in the framework of the Ambient Networks project (IST-027662), which is partially

funded by the Commission of the European Union. The views expressed are solely those of the authors and do not necessarily represent the views of their employers, the Ambient Networks project, or the Commission of the European Union. The authors would like to thank their colleagues from the Ambient Networks project and in particular Robert Hancock, for inspiring discussions. This paper is based on joint work in the project. Cornelia Kappler has performed this work while being with Nokia Siemens Networks, Berlin, Germany.

REFERENCES

- [1] 3GPP TS 23.402 v1.2.1, "3GPP System Architecture Evolution (SAE): Architecture enhancements for non-3GPP accesses", August 2007.
- [2] 3GPP TS 22.980 v8.1.0, "Network Composition", June 2007.
- [3] N. Niebert, A. Schieder, H. Abramowicz, G. Malmgren, J. Sachs, U. Horn, C. Prehofer, and H. Karl, "Ambient Networks – An architecture for communication networks beyond 3G", *IEEE Wireless Communications*, vol. 11, no. 2, pp. 14–21, April 2004.
- [4] N. Niebert, A. Schieder, J. Zander, and R. Hancock (Eds.), *Ambient Networks, Co-operative Mobile Networking for the Wireless World*, Wiley, April 2007.
- [5] C. Kappler, P. Mendes, C. Prehofer, P. Pöyhönen, and D. Zhou, "A framework for self-organized network composition", *Proc. Autonomic Communication (LNCS vol. 3457)*, Berlin, Germany, October 2004.
- [6] C. Kappler, N. Akhtar, R. Campos, and P. Pöyhönen, "Network composition using existing and new technologies", *Proc. IST Mobile and Wireless Summit*, Dresden, Germany, June 2005.
- [7] IETF MANET WG, www.ietf.org/html.charters/manet-charter.html
- [8] V. Devarapalli, R. Wakikawa, A. Petrescu, and P. Thubert, *Network Mobility (NEMO) Basic Support Protocol*, RFC 3963, January 2005.
- [9] IEEE, *Draft Standard for Local and Metropolitan Area Networks: Media Independent Handover Services*, P802.21/D07.00, July 2007. Work in progress.
- [10] A. Rahman, U. Olvera-Hernandez, J.C. Zuniga, M. Watfa, and H.W. Kim, *Transport of Media-Independent Handover Messages over IP*, IETF Internet Draft draft-rahman-mipshop-mih-transport, July 2007. Work in progress.
- [11] R. Hancock and E. Hepworth, *Supporting Media Independent Handover Protocols with GIST*, IETF Internet Draft draft-hancock-mipshop-gist-for-mih, June 2006. Work in progress.
- [12] J. Mäkelä and K. Pentikousis, "Trigger management mechanisms", *Proc. Second IEEE International Symposium on Wireless Pervasive Computing (ISWPC)*, San Juan, Puerto Rico, USA, February 2007.
- [13] R. Hancock, G. Karagiannis, J. Loughney, and S. Van den Bosch, *Next Steps in Signaling (NSIS): Framework*, IETF RFC 4080, June 2005.
- [14] N. Akhtar, R. Campos, C. Kappler, P. Pääkkönen, P. Pöyhönen, and D. Zhou, "GANS: a signalling framework for dynamic interworking between heterogeneous networks", *Proc. IEEE VTC Fall 2006*, Montreal, Canada, September 2006.
- [15] H. Schulzrinne and R. Hancock, *GIST: General Internet Signalling Transport*, IETF Internet Draft, IETF Internet Draft draft-ietf-nsis-ntlp, February 2008. Work in progress.
- [16] P. Pöyhönen, N. Akhtar, R. Campos, C. Kappler, P. Pääkkönen, and D. Zhou, "DEEP - A generic name resolution protocol for heterogeneous networks", *Proc. Second IEEE ICCTA 2006*, Damascus, Syria, April 2006.
- [17] D. Zhou (Ed.), *Validated Composition and Compensation Architecture*, Ambient Networks public deliverable D26-G.2, December 2007.
- [18] C. Pinho, J. Ruela, K. Pentikousis, and C. Kappler, "A protocol for event distribution in next-generation dynamic networks", *Proc. Fourth EURO-NGI Conference on Next Generation Internet Networks (NGI)*, April 2008, Krakow, Poland.